



## Float by Cavitation

Equipment for the Physical-Chemical treatment by flotation (DW CAF)

The float by cavitation DW CAF is an equipment designed **for the separation of fats, suspended solids and colloids from urban and industrial wastewater**, prior to a biological treatment or discharge to the municipal network, depending on the requirements.

Its design features give it a **high performance**, being a team able to operate for long periods of time without needing attention, with total **autonomy**.



### What is and how works the cavitation?

It's a hydrodynamic effect that occurs when steam cavities (micro bubbles) are created inside the fluid in which there are forces that respond to differences in pressure.



## How works our Physical-Chemical Treatment by Flotation?

The system is based on the **injection of micro bubbles of air to the waste water stream** to be treated, by means of a **submersible turbine** capable of generating a constant and uniform micro bubble flow, **without the aid of any external equipment**, it's not necessary use of blower, compressor, pump, or pressure tank.

The wastewater enters from below and is led to a central conduit where the micro bubble turbine is housed, suspended solids and fats adhere to the micro bubbles and are raised to the surface where a **surface sweeping system** separates them from the water and transports them to the solids outlet.

Heavier solids decant in the **conical bottom** and are extracted by a **lower purge**.

The treated water passes through a **siphon system** and leaves the top through an **adjustable dump** to choose the working height, adapting to the type of solid and quantity to be separated.

## Its construction consists of the following elements:

- **Tank body** made entirely of AISI 304 stainless steel, strong mechanically-welded construction, provided with liquid inlet and outlet, and **top discharge and bottom purge** of separate solids.
- **Superior structure** in stainless steel profiles for fastening the surface sweeping system.
- Strong double-walled for **surface sweeping system**, with **polyurethane scrapers** and **reducer motor**, robust and maintenance-free, which ensures uninterrupted operation of the equipment.
- **Integrated speed variator** to regulate the optimum speed of sweeping, and adapt it to the characteristics of each installation.
- **Turbine generator of micro bubbles** of special design equipped with anticellulating impeller, self-priming and of robust construction prepared for continuous work.



MODEL	NOMINAL FLOW	INSTALLED POTENCY KW	ENTRY FLANGE DN	OUTPUT FLANGE DN	PURGE FLANGE DN	FATS OUTPUT MM
DW CAF 1600	12 m3/h	0,87	100	100	80	200 x 220
DW CAF 1800	16 m3/h	0,87	125	125	80	220 x 220
DW CAF 2000	20 m3/h	0,87	150	150	80	250 x 250

### Advantages of Float by Cavitation (DW CAF):

- Simple and resistant equipment made of stainless steel.
- Very low power consumption compared to the competition.
- Low maintenance and economical.
- Simple installation and low initial cost.

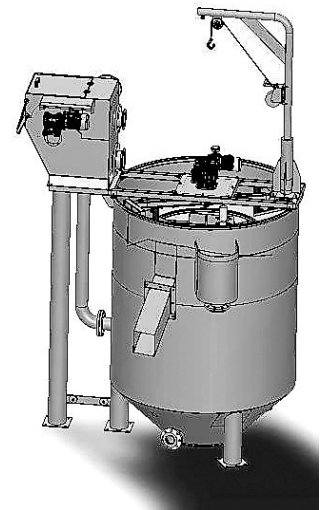

The DWCAF float by cavitation is suitable for use in urban sewage treatment plants such as polyvalent or specialized slaughterhouses, canning plants, pre-cooked food factories, dairy plants, cheese factories, or any type of agri-food industry where there is presence of fats, suspended solids and colloids.